

# MAC FAUCETS

## FA400 Autoluxe Faucets

### Installation Procedure:

Take a moment to view drawings and read “special Installation note” on page 4 of this manual before proceeding with installation. Connect Faucet Automator model FA400 exactly as shown in drawing, with sensor cable connection at left. Failure to install Faucet Automator Model FA400 exactly as shown will result in premature product failure and will void all warranties including extended warranty. Also, do not forget step 7.

1. Make sure surface area is clean and free of debris.
2. **\*\*If using deck plate, place plate on deck immediately over center sink hole\*\*.**  
Install new faucet by placing sensor wire through the hole designated for spout.  
Make sure that wire is not pinched or cut during installation. **Cutting or severely crimping sensor wire will cause faucet to malfunction and will also void warranty.** Sensor wire is specifically designed to resist damage, simple careful steps and common sense is all that is necessary for a complete and rewarding installation process. *You may use silicon or similar sealer between faucet and deck plate.*
3. Affix faucet above plate (if used).
4. Slide stainless steel washer over faucet shank. Insert sensor wire through special “C” groove in washer. Install retainer nut over faucet shank and tighten. (Do Not Over Tighten). Remove 3/8”- 1/2” brass bushing from package. Wrap Teflon tape or plumber’s putty around faucet shank clockwise and fasten bushing on to faucet shank.
5. Remove stainless steel braided hose from package and fasten to brass bushing.
6. Locate a spot on the wall that you feel is suitable for installing Faucet Automator FA400. The spot selected should be within reach of braided hose and sensor wire.  
Place Faucet Automator FA400 against the wall and mark the spots (2) where mounting holes will be. Using drill size ¼” drill 2 holes, insert supplied anchors in the holes.
7. Remove rubber band (or tape) that fastens the Faucet Automator’s cover to its base. Remove black square rubber cap off battery compartment, plug battery wire harness into battery pack. Make sure that harness plug makes solid contact with battery pack. Place black square rubber cap back onto battery compartment. Using 4 small screws fasten Faucet Automator cover to base.
8. Faucet Automator FA400 using supplied fasteners.
9. Install shank hose to Faucet Automator’s water outlet (top).
10. Align groove in sensor wire plug with pin in Faucet Automator FA400 sensor receptacle, insert plug into receptacle, fasten plug nut by hand only. **DO NOT CROSS THREAD OR OVER TIGHTEN.**
11. Install supplied brass “T” to Faucet Automator’s water inlet (side).  
**Before proceeding to step 9, purge both hot and cold water lines for at least a minute each at high volume. Purging water lines clears out dirt and debris that would otherwise find its way to screen filter.**
12. **\*\*\*For single water source application install cold water supply hose to Faucet Automator’s water inlet. Do not install hot water supply hose only in single water source application as this may result in scalding injury..**
13. **\*\*\*For dual water temp system install supplied T to Faucet Automator’s water inlet (Do Not Forget O ring). Adjust water mix using angle stops.**  
Install hot and cold water supply hoses to T. Turn angle stops on. Check for leaks.

To enable the faucet to activate from a farther distance or to stay on longer after hands are removed, see “sensor range adjustment” section of this manual.

To increase or decrease water flow volume, see “flow rate adjustment” section of this manual.

### Operation:

Place hands under spout and directly in front of neck mounted sensor, water will begin to flow out in less than a second, water flow rate is governed by aerator and supply pressure, water temperature is governed by selection at angle stops, as well as water temperature in supply pipes. PLEASE REMEMBER, AUTOMATIC FAUCETS EMPLOY “PRESENCE” NOT “MOTION” SENSORS. AN IDLE OBJECT PLACED DIRECTLY UNDERNEATH SPOUT WILL IMMEDIATELY ACTIVATE FAUCET. Remove hands and water will cease to flow within 1-3 seconds.

If hands are left underneath spout for 60 seconds, water will automatically shut off. To initiate flow again move hands away from faucet and start at step 1.

When attempting to run water over small objects such as tooth brush, it may be necessary to bring object closer to sensor to initiate water flow, when water begins to flow, move object back under stream of water. Once user “gets the feel” of the faucet this step may be skipped.

### **Battery Replacement Instructions:**

Batteries should provide 12 to 24 months of reliable service mostly depending on the make of battery used and the frequency of usage among other factors. Battery weakness is indicated by constantly flashing led light within the sensor capsule. When replacing batteries please follow these simple steps:

1. Unfasten the 4 Philips screws at the sides of the Faucet Automator FA400 (these screws are none magnetic stainless steel).
2. Hold both water fittings down and carefully remove enclosure cover. **Cover holds solenoid valve in place and when removed, solenoid valve may fall out. Use tape to hold solenoid valve in place while enclosure cover is removed.**
3. Remove the black square rubber cap off the battery compartment.
4. Pull battery pack out and disconnect from wire harness.
5. Replace batteries with **4 AA Alkaline** batteries, make sure batteries are placed in their proper position.
6. Re-install battery pack by re-plugging wire harness. Make sure that harness plug makes solid contact with battery pack. Place black square rubber cap back on.
7. Test faucet prior to placing enclosure cover back on.
8. Place enclosure cover back on. Fasten 4 Philips screws.

### **Sensor Range Adjustment:**

Sensor range is adjusted for optimal performance prior to shipping faucet. However, it may be necessary to adjust sensor range in the field.

1. Remove Faucet Automator’s enclosure cover (see battery replacement instruction for enclosure cover removal and installation).
2. When enclosure cover is removed, look for square blue “pot” with white plastic Philips screw that is placed approximately in the middle of the resin encased electronics. (There is only one electronic component that is accessible to you in the electronic board, it is impossible to go wrong with this step).
3. For longer sensor range turn white plastic screw clockwise, for shorter range turn screw counterclockwise. **Be very careful not to damage plastic screw.** The plastic screw is **very fragile**; unlike step 3 you could go wrong with this step.
4. When satisfied with sensor range, place enclosure cover back on.

**Please note: Sensors that are adjusted for longer range may be triggered unnecessarily by individuals walking in front of sink. Please adjust sensor range with that in mind.**

### **Flow Rate Adjustment:**

Flow rate is governed by supply pressure and the type of aerator used on the faucet. When necessary adjust flow rate as follows:

1. Remove Faucet Automator’s enclosure cover (see battery replacement instruction for enclosure cover removal and installation).
2. When enclosure cover is removed, look for stop at the inlet of the chrome plated brass valve, the stop is in the form of a brass screw that is usually not chrome plated.
3. To lessen flow rate turn screw clock wise, several turns may be needed.
4. After the desired flow rate is reached, place Faucet Automator’s cover back on.

### **Filter maintenance:**

**Read carefully before attempting to clean filter. Make sure that you have adjustable wrench or 5/16” Allen wrench.**

Although the Faucet Automator FA400 employs one of the largest filter screens of its kind, filter screen may become restricted or severely clogged due to floating debris in water supply pipes. The frequency of recommended service depends on the age of building, make up of pipes and quality of water among other factors. Restricted filter diminishes faucet performance and, in some cases, may damage faucet. A restricted filter manifests itself in reduced water flow out of faucet.

When necessary, clean filters as follows:

1. Unfasten both hoses that are connected to Faucet Automator FA400.
2. Unplug sensor wire by unscrewing sensor wire nut first, then pulling sensor wire out. To prevent damage to sensor wire **Do Not Pull Wire, Pull Wire Plug.**
3. Uninstall faucet Automator FA400 from wall mount, place on horizontal surface over an absorbent cloth.
4. Unfasten the 4 Philips screws at the sides of the Faucet Automator FA400 (these screws are none magnetic stainless steel).

5. Remove enclosure cover.
6. Unplug solenoid wires (yellow and white) **Do Not Sever Wires.**
7. Remove complete solenoid valve out of enclosure.
8. Using adjustable wrench (or 5/16" Allen wrench), unfasten and remove filter cap.
9. Pull out filter screen and clean over running water.
10. Make sure that filter screen valve cavity is clean and free of debris.
11. Re-install filter screen and fasten filter cap using Allen wrench. **Make sure O ring is wet prior to installing filter cap back on.**
12. Re-assemble Faucet Automator FA400 and re-install hoses and sensor wire.

## **Trouble Shooting:**

*Faucet does not operate, red light does not blink:*

1. Hands are not placed properly under spout and inline with sensor.
2. Batteries need replacing, replace batteries, see battery replacement instructions.
3. Batteries installed improperly in battery pack, battery harness not plugged in properly, see installation instruction, and battery replacement instructions.
4. Sensor wire loose, unplugged, plugged improperly, plug sensor wire properly. See installation instructions.
5. Sensor range requires adjustment, see sensor range adjustment instructions.
6. Sink is raised above counter and blocking "sensor's vision", reinstall properly.

*Faucet does not operate, red light blinks in response to approaching objects:*

1. No water, very low water pressure in supply pipes, supply valves closed.
2. Water pressure very high, well above 115 PSI.
3. Screen filter severely clogged up.
4. Supply hoses severely kinked.
5. Batteries low or defective, replace batteries.

*Faucet operates on and off "by it self":*

1. Sensor range adjusted too long, and must be adjusted for shorter range. See sensor range adjustment section of this manual.
2. Objects such as sink lip may be present in close proximity to sensor.
3. (Rare) Severe transient infrared signal present in the environment, probably caused by a defective neon light.

*Faucet leaks, drips:*

Constant leaks or drips indicate defective solenoid valve, send Faucet Automator for repair or contact an authorized plumbing professional.

*Faucet continues to run for 30 -60 seconds after hands are removed:*

This very rare condition generally occurs due to over sensitivity on the part of the sensor, system water pressure well above 70psi and an over lit bathroom environment. This condition is always field curable.

1. Turn down water flow rate, see water flow rate adjustment.
2. Replace aerator with 0.5 GPM aerator (when possible).
3. Adjust sensor range to "shorter". See sensor range adjustment instructions.

*Loud thump noise when faucet turns on and off.*

This is an issue commonly associated with diaphragm type valves such as washing machine valves, dishwasher valves, etc. The noise is generally present in the piping system. One clear winner remedy is to:

1. Lower water flow rate (see flow rate adjustment section of this manual).
2. Install "hammer arrestors" in close proximity to your automatic faucet. Please consult a plumbing professional for this task.

### **LIMITED WARRANTY**

MAC FAUCETS WARRANT THIS FAUCET TO BE FREE OF DEFECTS FOR A PERIOD OF ONE YEAR FROM DATE OF PURCHASE. MAC FAUCETS WILL REPLACE, FREE OF CHARGE, DURING THIS WARRANTY PERIOD, PARTS THAT PROVE DEFECTIVE WHEN PROPERLY INSTALLED AND UNDER NORMAL USE AND SERVICE. DAMAGE THAT OCCURS AS A RESULT OF ABUSE, IMPROPER INSTALLATION, ENVIRONMENTAL CONDITIONS, OR IMPROPER APPLICATION WILL VOID THIS WARRANTY. PRODUCTS MUST BE SHIPPED WITH POSTAGE AND HANDLING PREPAID, ALONG WITH DATED PROOF OF PURCHASE. THIS WARRANTY DOES NOT COVER INSTALLATION OR ANY OTHER LABOR CHARGES. IT DOES NOT COVER SHIPPING AND HANDLING OF BOTH REPLACEMENT PARTS AND RETURNED DEFECTIVE PARTS. PRODUCTS OR COMPONENTS THAT HAVE BEEN ALTERED OR IN ANY WAY MODIFIED WILL NOT BE COVERED UNDER THIS WARRANTY. REPLACEMENT PARTS ARE UNDER WARRANTY ONLY FOR THE REMAINING PERIOD UNDER THE INITIAL WARRANTY. SOME STATES DO NOT ALLOW FOR EXCLUSION OF INCIDENTAL OR CONSEQUENTIAL DAMAGE.

# Special Installation Note

Automatic faucets are design to perform properly in a variety of applications. There are some conditions, however, that may adversely impact the faucet's ability to perform. Please note the following conditions prior to installing you new faucet:

1. Your automatic faucet is designed for indoor applications. This faucet is not designed for outdoor applications.
2. Avoid installing your new faucet in direct sunlight. Direct sunlight that is focused on sensor will temporarily disable faucet's sensing capabilities.
3. If you choose to install your faucet to one water source only, **do not install to hot water only** as this may result in scalding injury.
4. **Important:** Before connecting supply line to Faucet Automator, purge both hot and cold water lines for at least one minute each at high volume. Purging water lines clears out dirt and debris that would otherwise find its way to screen filter within the solenoid valve.
5. **Important:** Do not use pipe putty on water connection to faucet. Pipe putty may cause immediate and irreversible damage to solenoid valve. Please use Teflon tape instead.
6. **Important:** If you do not plan on using faucet immediately after installation (within 30 days of installation), disconnect water supply lines to faucet and unload the water pressure that may be present in faucet. This will keep new solenoid valve components from bonding together under high pressure.

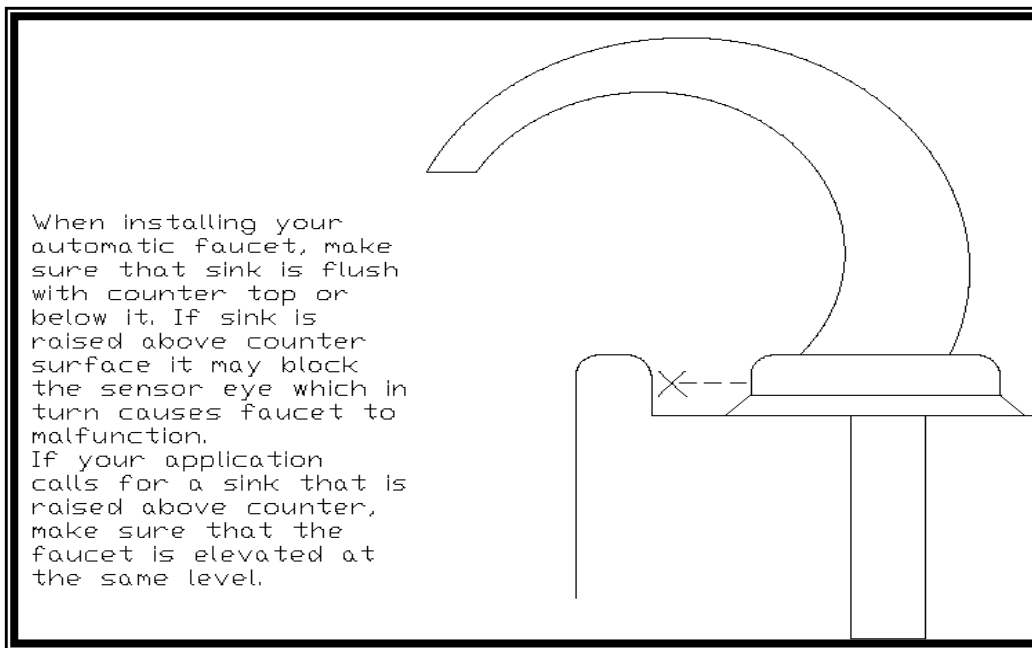

# MAC FAUCETS

Installation/Connection Drawings

& Rough In

For Faucet Models

FA400-102

FA400-103

FA400-104

FA400-106

FA400-109

FA400-115

FA400-116

FA400-118

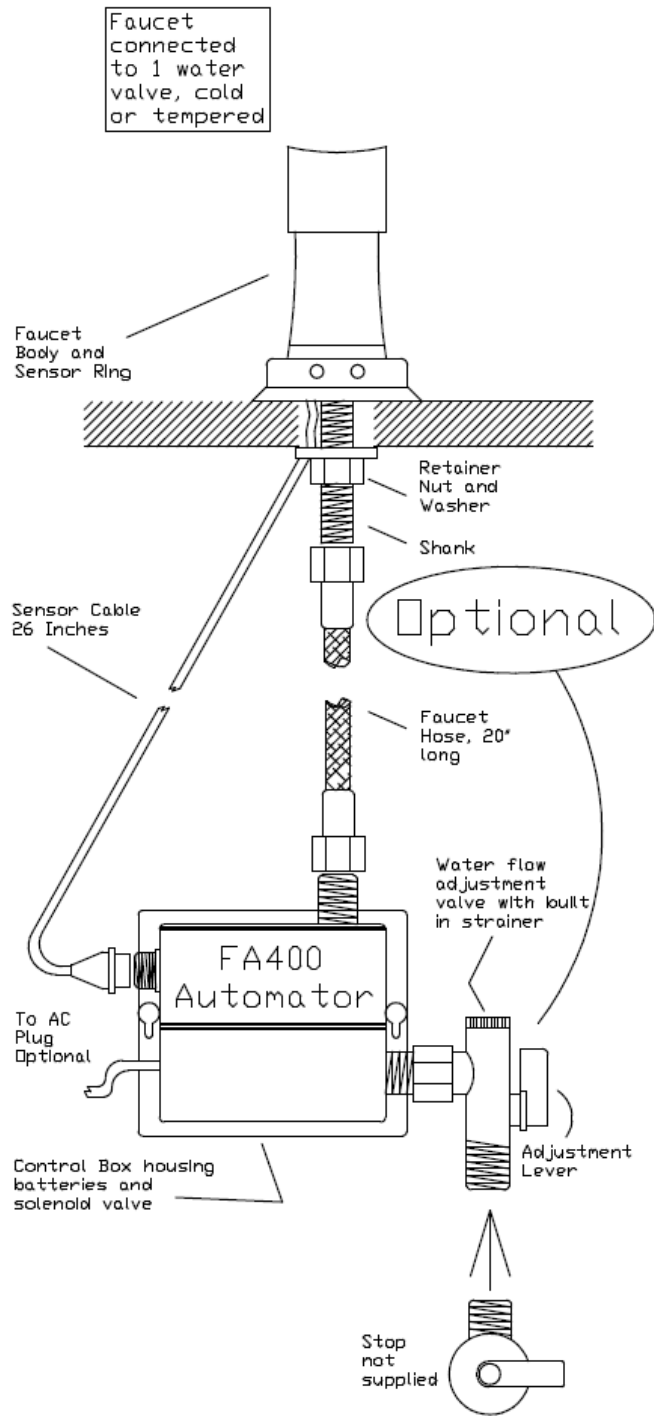

Autoluxe

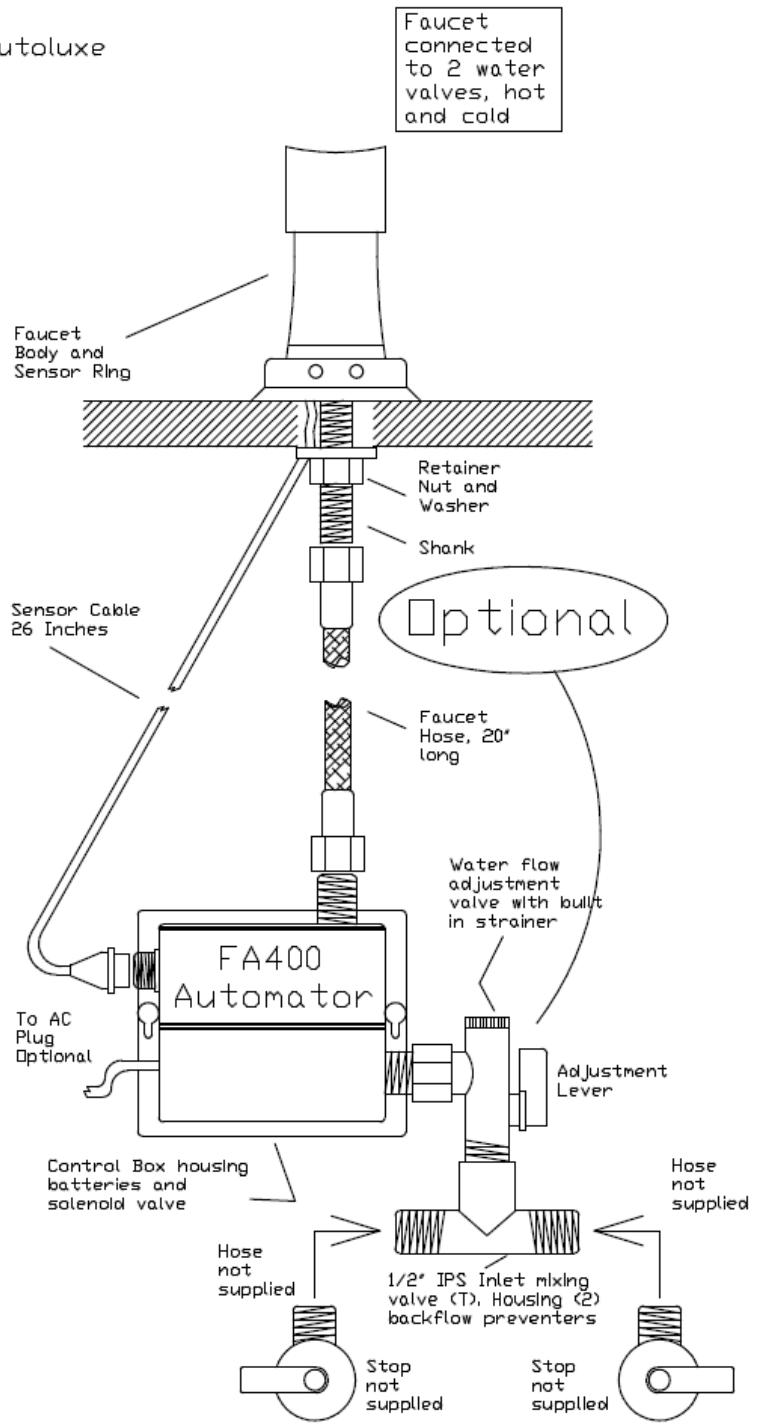

# MAC FAUCETS

Rough-In Faucets, Water  
mixing valves, Soap dispensers

## Top View

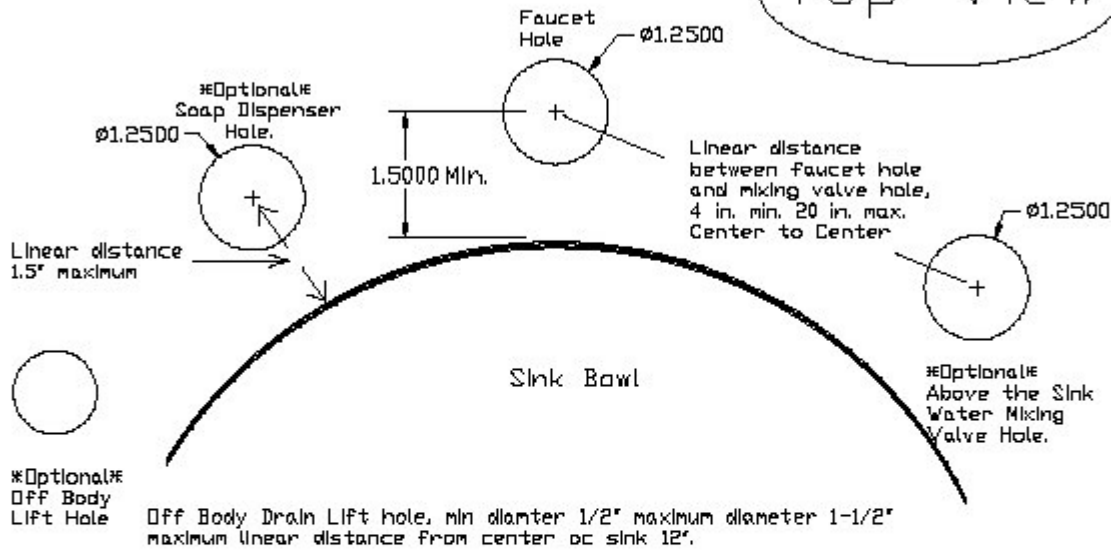

## Side View

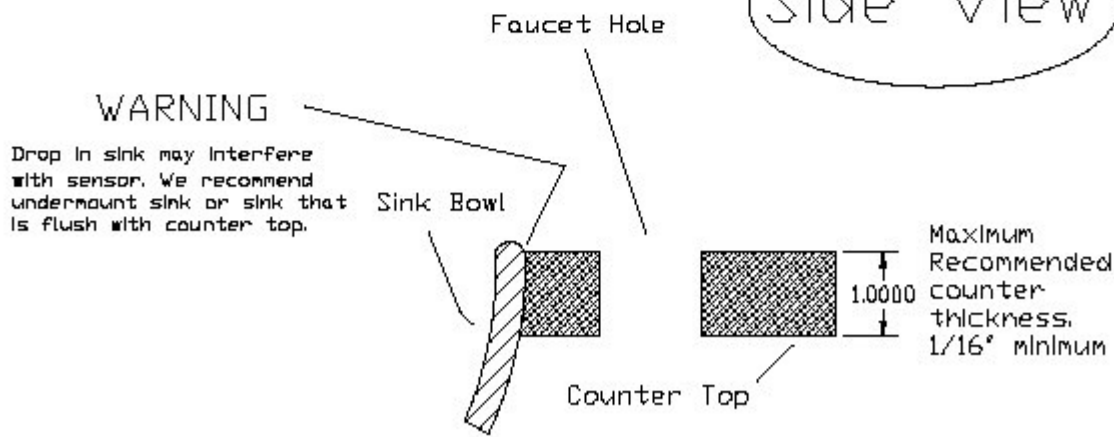

# Faucet Automator™ Model FA400

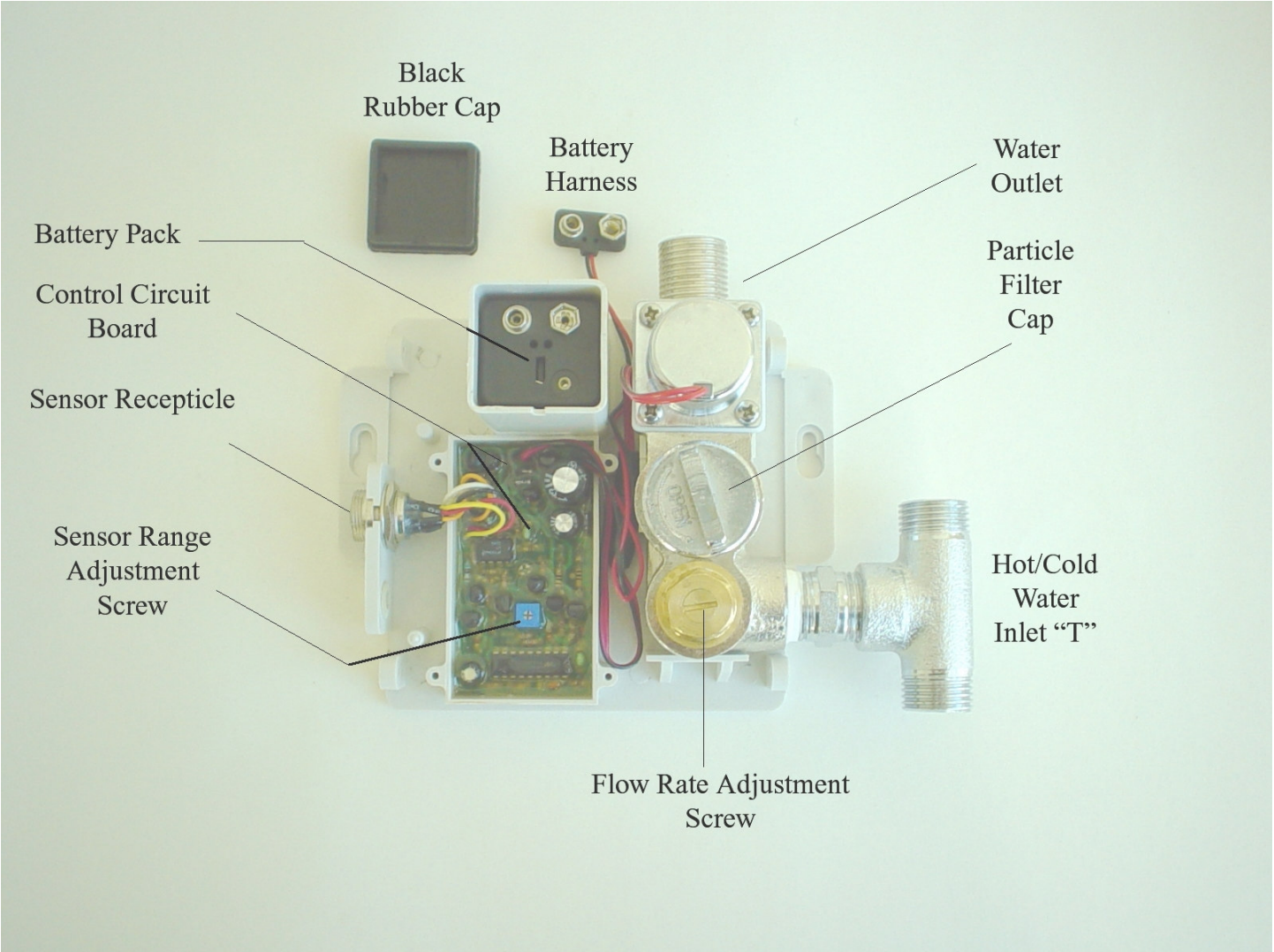

**MAC FAUCETS**  
1289 North Post Oak. Suite 160  
Houston, TX 77055  
Tel 866.558.3200 – Fax 310.919.3073  
[www.macfaucets.com](http://www.macfaucets.com)  
email: [sales@electronicfaucets.com](mailto:sales@electronicfaucets.com)