

MAC FAUCETS

Owner's Manual

Models: FA444

Installation procedure:

1. **Take a moment to view drawings and read “special Installation note” on page 3 of this manual before proceeding with installation. Connect Faucet Automator model FA444 exactly as shown in drawing, with sensor cable connection at bottom. Failure to install Faucet Automator Model FA444 as shown will result in premature product failure and will void all warranties including extended warranty.**
2. ****If using deck plate, place plate on deck immediately over center sink hole**.** Install new faucet by placing sensor wire and hose (faucets with integral hose) through the hole designated for spout. Make sure that wire is not pinched or cut during installation. **Cutting or severely crimping sensor wire will cause faucet to malfunction and will also void all warranties.**
3. **Faucets with integral hose go to step 5.** Affix faucet above plate (if used). Slide retainer washer over faucet shank with set screw deep placed in shank groove. Insert sensor wire through special groove in washer. Install retainer nut over faucet shank and tighten.
4. Remove the stainless steel braided hose from package, fasten to faucet shank. **Go to step 6.**
5. Place rubber ring (if used) at the bottom of the faucet. Affix faucet above plate (if deck plate is used). Use 2 screws, 2 nuts, and 1 retainer washer to fasten faucet to deck.
6. Locate spot on the wall that you feel comfortable installing Faucet Automator FA444. The spot selected should be within reach of braided hose and sensor wire. The selected spot should also be away from possible water contamination.
7. Mount Faucet Automator FA444 using supplied fasteners. **Be careful to mount box exactly as shown in drawings.**
8. Install shank hose to Faucet Automator's water outlet (top).
9. Align groove in sensor wire plug with pin in Faucet Automator FA444 sensor receptacle, insert plug into receptacle, fasten plug nut by hand only. **DO NOT CROSS THREAD.**

Before proceeding to step 9, purge both hot and cold water lines for at least a minute each at high volume. Purging water lines clears out dirt and debris that would otherwise find its way to screen filter within the solenoid valve.

10. *****For single water source system install cold water supply hose to Faucet Automator's water inlet, absolutely do not substitute hot water for cold as this may lead to scalding injuries.**
11. *****For dual water temp system install supplied T to Faucet Automator's water inlet (Do Not Forget O ring).**
12. Install hot and cold water supply hoses to T in no particular order.
13. Turn angle stops on. Check for leaks.

Operation:

1. Place hands under spout and directly in front of neck mounted sensor, water will begin to flow out in less than a second, water flow rate is governed by aerator and supply pressure, water temperature is governed by selection at angle stops, as well as water temperature in supply pipes. PLEASE REMEMBER, AUTOMATIC FAUCETS EMPLOY “PRESENCE” NOT “MOTION” SENSORS. AN IDLE OBJECT PLACED DIRECTLY UNDERNEATH SPOUT WILL IMMEDIATELY ACTIVATE FAUCET.
2. Remove hands and water will cease to flow within 1-3 seconds.
3. If hands are left underneath spout for 60 seconds, water will automatically shut off. To initiate flow again move hands away from faucet and start at step 1.
4. When attempting to run water over small objects such as tooth brush, it may be necessary to bring object closer to sensor to initiate water flow, when water begins to flow, move object back under stream of water. Once user “gets the feel” of the faucet this step may be skipped.

Battery Replacement Instructions:

Batteries should provide 12 to 24 months of reliable service mostly depending on the make of battery used and the frequency of usage among other factors. Battery weakness is indicated by constantly flashing led light within the sensor capsule. When replacing batteries please follow these simple steps:

1. Unfasten the 4 Philips screws at the top of the Faucet Automator FA444. *TWS box, proceed to step 4.*
2. Hold both water fittings down and carefully remove enclosure cover.
3. Pull black battery holder out. **Be careful not to damage wire.**
4. Replace batteries with **4 AA Alkaline** batteries, make sure batteries are placed in their proper position.
5. Re-install battery pack into the Faucet Automator.
6. Test faucet prior to placing enclosure cover back on.
7. Place enclosure cover back on. Fasten 4 Philips screws.

Trouble Shooting:

Faucet does not operate, red light does not in response to approaching objects:

1. Hands are not placed properly under spout and inline with sensor.
2. Batteries need replacing, replace batteries, see battery replacement instructions.
3. Batteries installed improperly in battery pack, battery harness not plugged in properly, see installation instruction, and battery replacement instructions.
4. Sensor wire loose, unplugged, plugged improperly, plug sensor wire properly. See installation instructions.
5. Sensor range requires adjustment, see sensor range adjustment instructions.
6. Sink is raised above counter and blocking “sensor’s vision”, reinstall properly.

Faucet does not operate, red light blinks in response to approaching objects:

1. No water, very low water pressure in supply pipes, supply valves closed.
2. Water pressure very high, well above 115 PSI.
3. Screen filter severely clogged up.
4. Supply hoses severely kinked.
5. Batteries low or defective, replace batteries.

Faucet operates on and off “by it self”:

1. Sensor range adjusted too long, and must be adjusted for shorter range. See sensor range adjustment section of this manual.
2. Objects such as sink lip may be present in close proximity to sensor.
3. (Rare) Severe transient infrared signal present in the environment, probably caused by a defective neon light.

Faucet leaks, drips:

Constant leaks or drips indicate defective solenoid valve, send Faucet Automator for repair or contact an authorized plumbing professional.

Loud thump noise when faucet turns on and off:

This is an issue commonly associated with diaphragm type valves such as washing machine valves, dishwasher valves, etc. The noise is generally present in the piping system. Clear winner remedies are to:

1. Lower water flow rate (see flow rate adjustment section of this manual).
2. Install “hammer arrestors” in close proximity to your automatic faucet. Please consult a plumbing professional for this task.
3. Problem may be caused by defective angle stop. Replace angle stop.

Faucet continues to run for 30 -60 seconds after hands are removes:

This very rare condition generally occurs due to over sensitivity on the part of the sensor, system water pressure well above 100psi, and/or bathroom lighting setting. This condition is always field curable.

1. Turn down water flow rate, see water flow rate adjustment.
2. Replace aerator with 0.5GPM aerator (when possible).
3. Adjust sensor range to “shorter”. See sensor range adjustment instructions.

Faucet runs if NO hands are present, shuts off when hands are present under faucet, (works backwards).

Solenoid valve wire plugged in backwards. Unplug solenoid wire from electronics, rotate 180 degrees, re-insert the 2 plug ends together. **It is extremely important that you have flash light present when plugging solenoid wire correctly.**

Runaway faucet, water runs out of faucet continuously, longer than 1 minute, does not stop.

1. Make sure batteries are installed properly, if A.C., make sure that power is present at wall receptacle.

2. Make sure Faucet Automator is properly oriented on the wall, see drawings below.
3. Make sure that sensor wire from faucet is plugged into Faucet Automator.
4. Make sure that sensor wire is not cut or broken specially near mounting nut and washer immediately below deck.
5. Make sure that water is plumbed correctly into Faucet Automator, Water in to “inlet”, water out from “Outlet” see Drawings.
6. If items 1 to 5 are OK, please contact Factory for more tips on your particular installation.

Special Installation Note

Automatic faucets are design to perform properly in a variety of applications. There are some conditions, however, that may adversely impact the faucet’s ability to perform. Please note the following conditions prior to installing you new faucet:

1. Your automatic faucet is designed for indoor applications. This faucet is not designed for outdoor applications.
2. Avoid installing your new faucet in direct sunlight. Direct sunlight that is focused on sensor will temporarily disable faucet’s sensing capabilities.
3. If you choose to install your faucet to one water source only, **do not install to hot water only** as this may result in scalding injury.
4. **Important:** Before connecting supply line to Faucet Automator, purge both hot and cold water lines for at least one minute each at high volume. Purging water lines clears out dirt and debris that would otherwise find its way to screen filter within the solenoid valve.
5. **Important:** Do not use pipe putty on water connection to faucet. Pipe putty may cause immediate and irreversible damage to solenoid valve. Please use Teflon tape instead.
6. **Important:** If you do not plan on using faucet immediately after installation (within 30 days of installation), disconnect water supply lines to faucet and unload the water pressure that may be present in faucet. This will keep new solenoid valve components from bonding together under high pressure.

Drawings below does not apply to FA444-41 and FA444-43

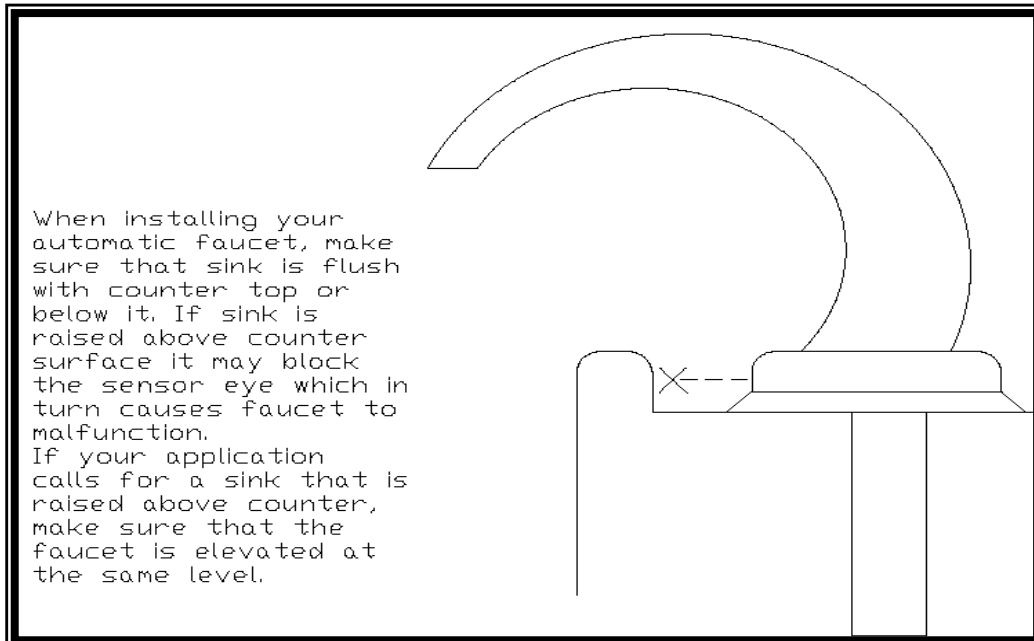

MAC FAUCETS

Installation/Connection Drawings

& Rough In

For Faucet Models

FA444-11

FA444-12

FA444-15

FA444-31

FA444-63

FA444-41

FA444-43

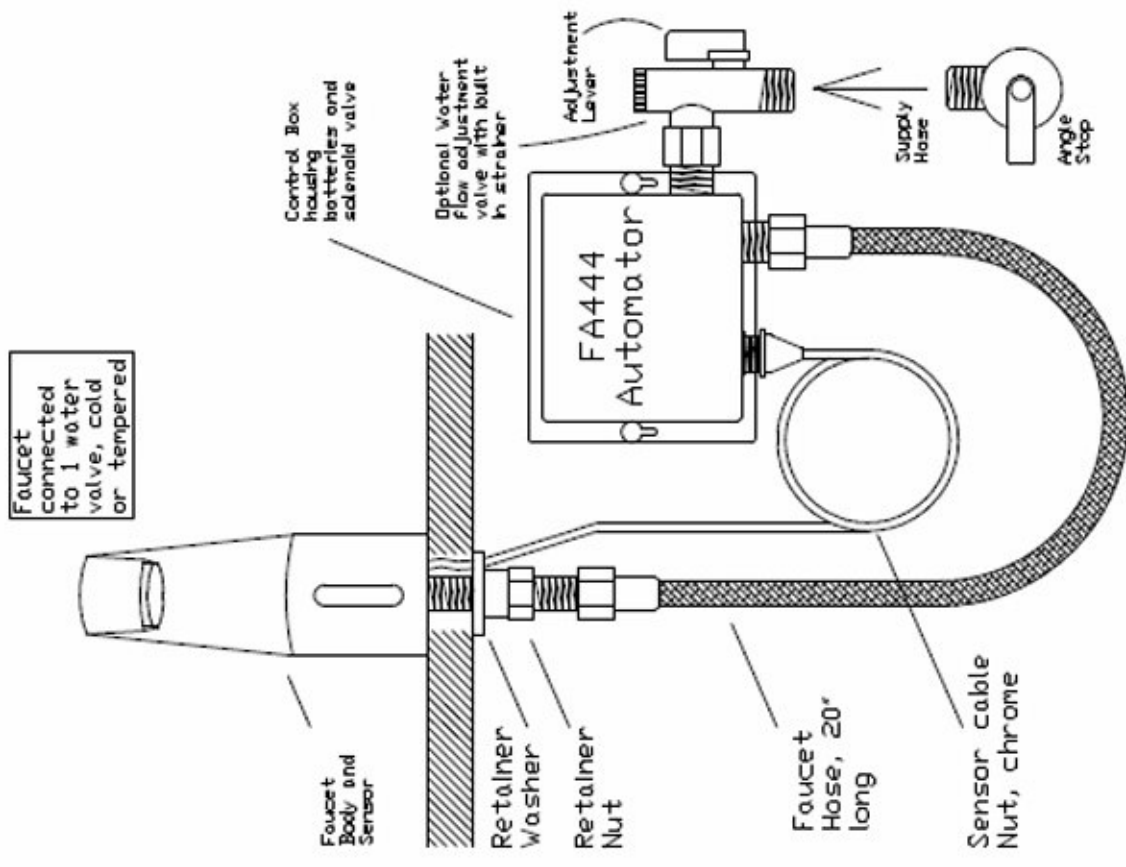
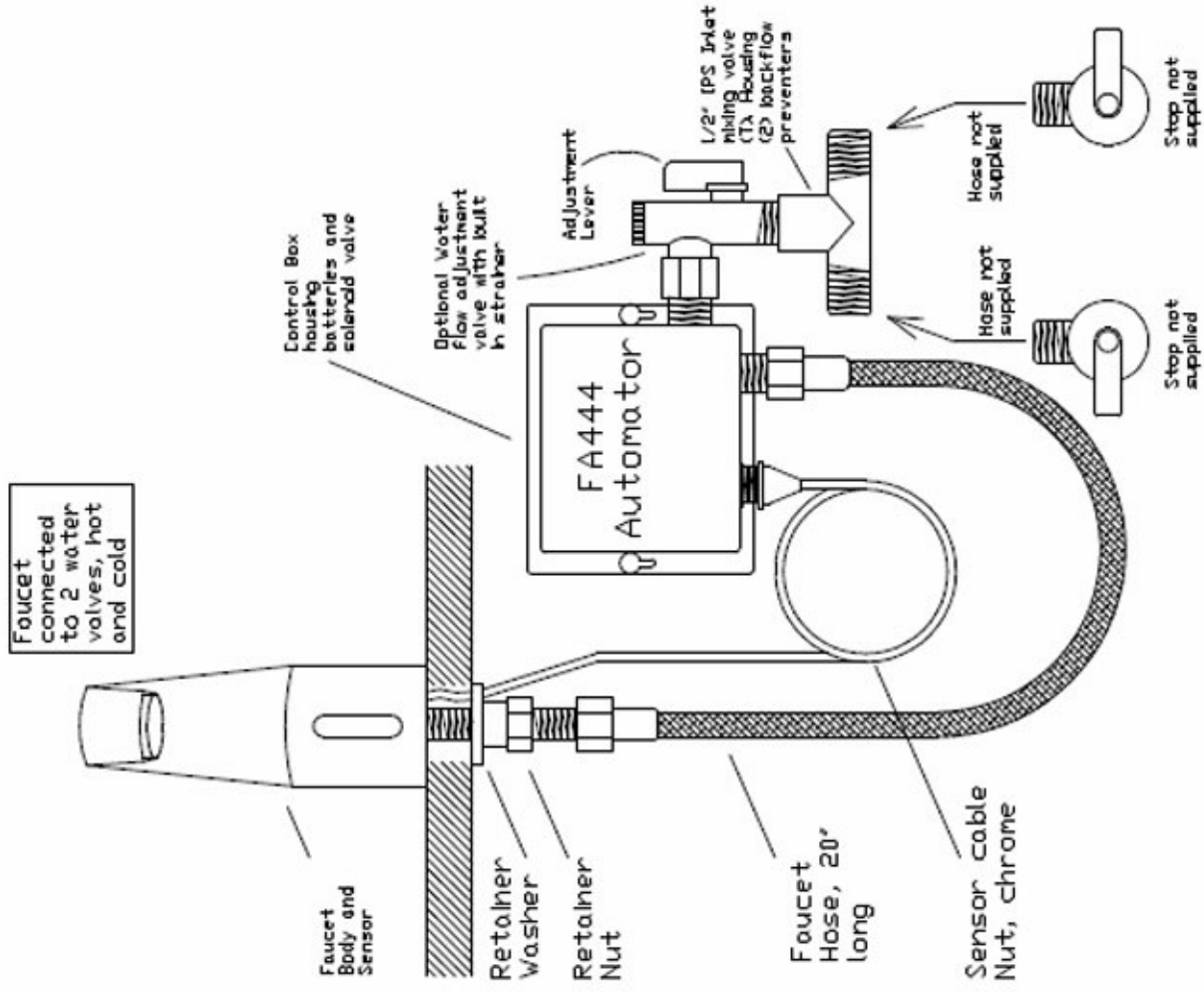

MAC FAUCETS

Rough-In Faucets, Water mixing valves, Soap dispensers

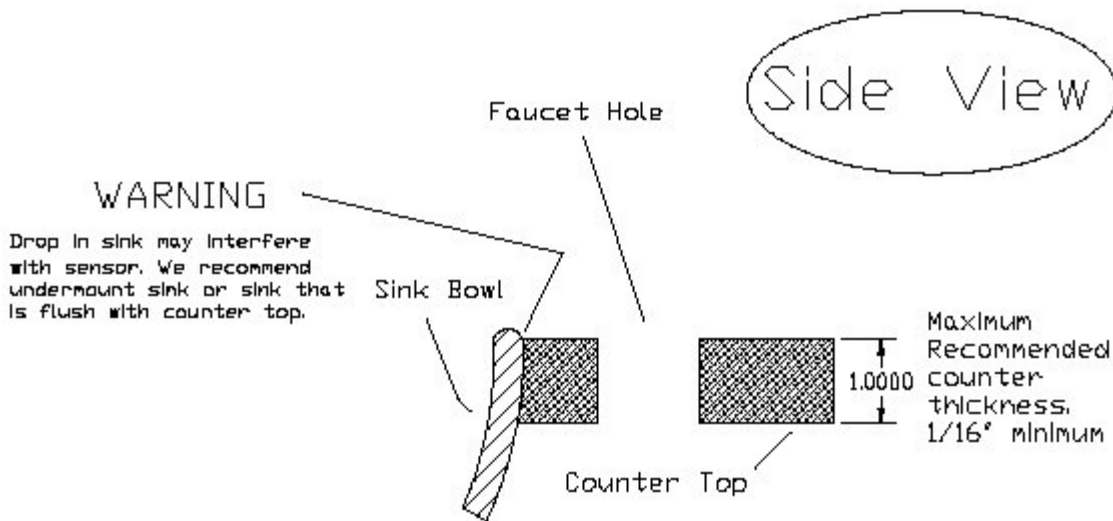
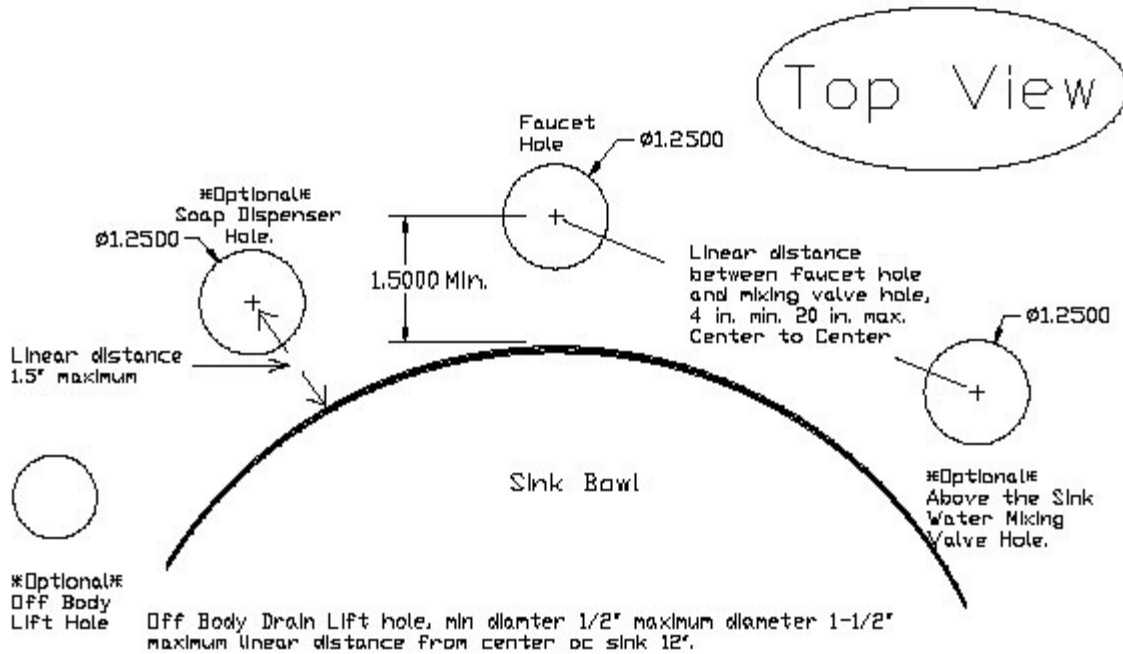

LIMITED WARRANTY

MAC FAUCETS WARRANT THIS FAUCET TO BE FREE OF DEFECTS FOR A PERIOD OF ONE YEAR FROM DATE OF PURCHASE. MAC FAUCETS WILL REPLACE, FREE OF CHARGE, DURING THIS WARRANTY PERIOD, PARTS THAT PROVE DEFECTIVE WHEN PROPERLY INSTALLED AND UNDER NORMAL USE AND SERVICE. DAMAGE THAT OCCURS AS A RESULT OF ABUSE, IMPROPER INSTALLATION, ENVIRONMENTAL CONDITIONS, OR IMPROPER APPLICATION WILL VOID THIS WARRANTY. PRODUCTS MUST BE SHIPPED WITH POSTAGE AND HANDLING PREPAID, ALONG WITH DATED PROOF OF PURCHASE. THIS WARRANTY DOES NOT COVER INSTALLATION OR ANY OTHER LABOR CHARGES. IT DOES NOT COVER SHIPPING AND HANDLING OF BOTH REPLACEMENT PARTS AND RETURNED DEFECTIVE PARTS. PRODUCTS OR COMPONENTS THAT HAVE BEEN ALTERED OR IN ANY WAY MODIFIED WILL NOT BE COVERED UNDER THIS WARRANTY. REPLACEMENT PARTS ARE UNDER WARRANTY ONLY FOR THE REMAINING PERIOD UNDER THE INITIAL WARRANTY. SOME STATES DO NOT ALLOW FOR EXCLUSION OF INCIDENTAL OR CONSEQUENTIAL DAMAGE.

MAC FAUCETS

1289 North Post Oak. Suite 160

Houston, TX 77055

Tel 866.558.3200 – Fax 310.919.3073

www.macfaucets.com

email: sales@electronicfaucets.com